

Thank you for purchasing the SXV200V1 SiriusXM Connect Vehicle Tuner Kit.

This kit comes with everything you need to add Satellite Radio to your SiriusXM-Ready headunit. Consult your headunit User Guide for features and detailed operational instructions.

For questions or support, please visit www.siriusxm.com or call 1-866-635-2349.

What's In the Box?

The SXV200V1 kit includes the following:

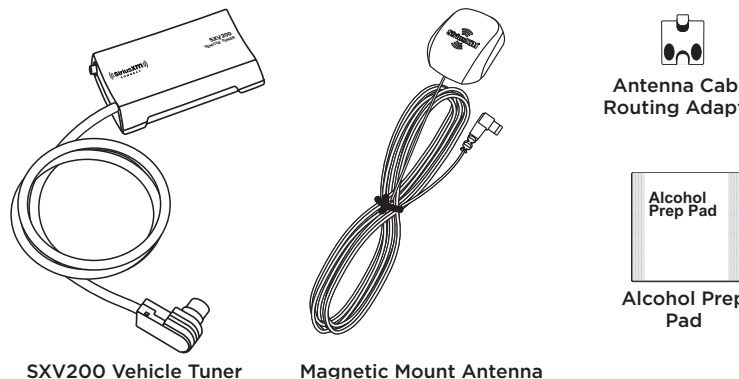

Check Your Headunit For Compatibility

If your headunit has the official SiriusXM-Ready logo it is compatible with the SXV200 Vehicle Tuner. All SiriusXM-Ready headunits include a dedicated connector, allowing for quick and easy connection of the SXV200 tuner.

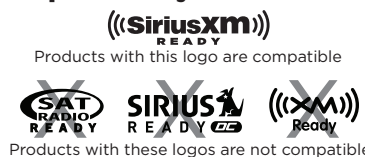

Install the Magnetic Mount Antenna

Proper placement of the Magnetic Mount Antenna is very important. Consult a professional installer if you are uncomfortable with installing the antenna yourself. More detailed installation instructions and illustrations can be found at www.siriusxm.com/installation and clicking on the **XM Vehicle Installation** link.

- Locate the Magnetic Mount Antenna on the outside of your vehicle on a horizontal surface that always faces the sky.
- Avoid placing the antenna near obstacles that could block a clear view of the sky (such as roof racks, other antennas like AM/FM, cellular, and GPS), preventing the satellite signal from reaching the antenna.

Select the Best Location for the Magnetic Mount Antenna

For most vehicles the best location is on the roof, centered above the rear window or front windshield. Consult a professional installer to find an alternate antenna mounting location if your vehicle roof is made from a non-magnetic material such as aluminum, fiberglass, or carbon fibre.

- **Sedan or Coupe:** Recommended mounting location is above the rear window or front windshield.
- **Pickup or SUV:** Recommended mounting location is above the front windshield.
- **Convertible:** Recommended mounting location is above the front windshield, or alternately on the trunk lid, on the front hood, or on top of the front fender.

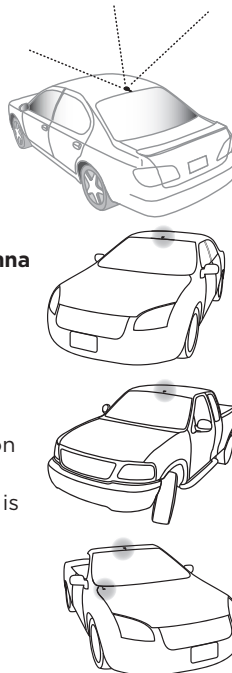

Route the Antenna Cable

If you are installing the antenna at the edge of the roof or hood, install the Antenna Cable Routing Adapter to direct the cable downward. Place the antenna cable into the groove of the adapter and slide the adapter down the cable until the adapter is flush with the bottom of the antenna.



Use care when routing the antenna cable into and through the vehicle interior, avoiding sharp objects that can damage the cable. Keep the antenna cable away from moving parts such as gas and brake pedals, trunk and door hinges, and sliding seat brackets.



Hide the antenna wire inside the vehicle cabin by routing the cable under the carpet and behind plastic trim, toward the headunit location. Coil and secure any excess cable in a hidden location, such as under the carpet, using wire ties (not included).

CAUTION! Do not kink or sharply fold the antenna cable.

1. Feed cable under rubber moulding around window.
2. Route cable out of window moulding and into weather-stripping around trunk opening.
3. Route cable along trunk wall and into cabin.
4. Route cable from trunk under interior trim, into cabin and towards front of vehicle.
5. Bring cable out from trim and route under carpet and behind the dash to the headunit. Coil and secure excess cable under carpet or behind dash.

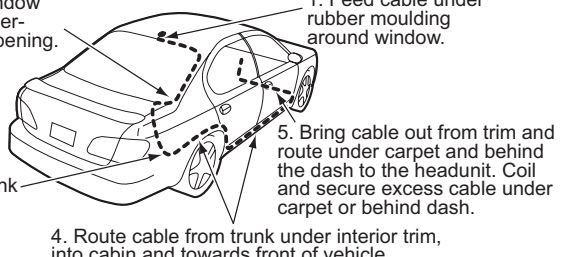

Make the Connections

You'll need to access the back of the SiriusXM-Ready headunit so you can plug the SXV200 Vehicle Tuner into it. This may require you to remove the headunit from the dashboard. If you are uncomfortable with this step, consult a professional installer.

Be sure to turn OFF the SiriusXM-Ready headunit before connecting the SXV200 Vehicle Tuner. Locate the SiriusXM connector on the headunit and connect the SXV200. The headunit may have a panel mount type connector, or it may have a pigtail type connector.

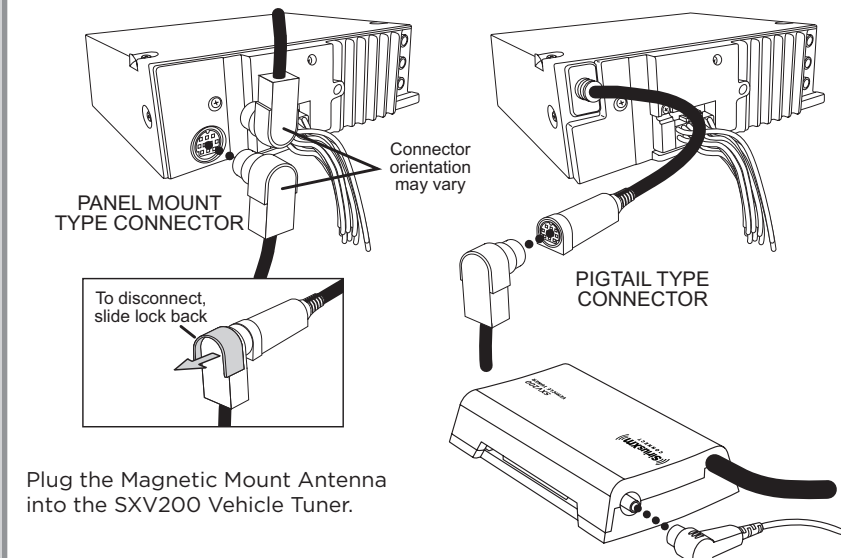

Secure the Tuner

Secure the SXV200 Vehicle Tuner behind the vehicle headunit location or under the dash using wire ties (not included).

Thread the wire ties through the molded brackets on the underside of the Tuner as shown. Then secure it to a bracket or wiring harness using the wire ties. Avoid brackets with sharp edges and any moving parts such as gas and brake pedals.

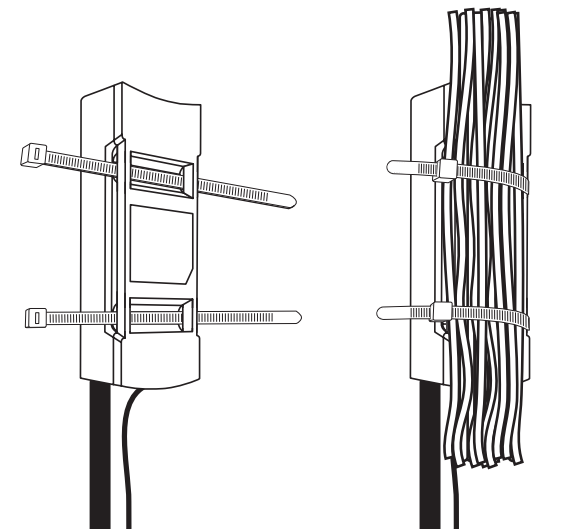

Reinstall the vehicle headunit if it had been removed from the dashboard.

Subscribe

Once the SXV200 Vehicle Tuner begins receiving the satellite signal, a courtesy period is initiated that allows you to tune to channels and listen to SiriusXM Radio programming for up to 5 days.

You can subscribe to the SiriusXM service anytime by following these steps:

- 1 Make sure your vehicle headunit is turned on and that Satellite Radio is selected. Verify that you are receiving the SiriusXM signal so that you can hear the SiriusXM audio.
- 2 Make a note of your Radio ID. You can find it on channel 0, on a label on the bottom of the packaging, and on the label on the bottom of your SXV200 Vehicle Tuner.

NOTE! The Radio ID does not use the letters I, O, S, or F.

- 3 Activate your service:
 - First see our Customer Agreement for complete terms at www.siriusxm.com and then:
 - Online: Go to www.siriusxm.com/activatenow
 - OR
 - By phone: Call **1-866-635-2349**

- 4 Activation usually takes 10 to 15 minutes, but may take up to an hour. We recommend that your vehicle headunit remain on until subscribed. When your service is activated, you will see the **SUBSCRIPTION UPDATED, PRESS ENTER TO CONTINUE** or similar message displayed on the headunit. Once subscribed, you can tune to channels in your subscription plan.
- 5 Activation signals can be sent again at any time by visiting www.siriusxm.com/refresh.

Troubleshooting

The troubleshooting information listed below is for general reference. Consult the User Guide for your SiriusXM-Ready headunit for specific operating instructions and advisory messages which may be displayed. Your headunit may display slightly different messages.

If you see this on the screen:	Try this:
No Signal (NoSignal)	<ul style="list-style-type: none"> Make sure that the vehicle is outdoors with a clear view of the southern sky. Make sure the Magnetic Mount Antenna is mounted outside of the vehicle. Move your antenna away from any obstructed area. For example, if you are parked in an underground garage, you should receive a signal after leaving the garage.
Check Antenna (Chek Antenna, CHK Antena, Chek Ant)	<ul style="list-style-type: none"> Make sure that the Magnetic Mount Antenna cable is firmly and securely plugged into the SXV200 Vehicle Tuner. Make sure the antenna cable is not bent or broken. Turn the headunit off, then on, to reset this message. If the message persists, most likely the antenna cable has been damaged. Replace the antenna.
Antenna Disconnected	Check the antenna connection to make sure it is fully plugged into the SXV200 Vehicle Tuner.
Antenna Cable Shorted	Replace the antenna.
Check Tuner (Chek Tuner, Chk Tunr)	Check the SXV200 Vehicle Tuner connection to the headunit and make sure it is plugged all the way in.
Channel Not Available (Chan Unavailable, Ch Unavailable, Ch Unavail, Ch Unavl)	The channel you have selected is not available.
Channel Not Subscribed (CH Unsubscribed, Chan Unsub, Ch Unsub)	The channel you have selected is not part of your current subscription plan. First see our Customer Agreement for complete terms at www.siriusxm.com , and then call 1-866-635-2349 to subscribe.

Subscription Updated- Press enter to continue (or similar message)	Your subscription has been updated; press the appropriate button (or other identified key) to continue.
If this happens:	Try this:
You do not receive all the channels to which you subscribe	<ul style="list-style-type: none"> If you have not yet activated your service, call 1-866-635-2349. Go to www.siriusxm.com/refresh and follow the directions to refresh your SXV200 Vehicle Tuner.
No song title or artist name is displayed	The information may not be available or updates may be in progress.
Traffic and Weather channels sound different from other channels	These channels use a different audio technology than other channels, so they often sound different from other channels.
Audio fades or has static when listening	<ul style="list-style-type: none"> Check all the cables for a firm and secure connection. Be sure that your headunit is correctly wired to the vehicle electrical system.

Specifications

Tuner	
Dimensions	3.42 in (W) x 2 in (H) x 0.7 in (D) 87mm (W) x 51.8mm (H) x 17.9mm (D)
Weight	3 oz (85 g)
Pigtail Cable Length	25.6 in (650 mm)
Power Requirements	12v DC, 0.3 A (MAX) (supplied by headunit)
Operating Temperature	-4°F to +158°F (-20°C to +70°C)
Antenna	
Type	Magnetic Mount
Connector	SMB
Cable Length	23 ft (7 m)

Network Operation XM Network Only
Specifications are subject to change without notice.

FCC Statement

The user is cautioned that changes or modifications not expressly approved by Sirius XM Radio Inc. can void the user's authority to operate this device. This device complies with Part 15 of the FCC Rules. Operation is subject to the following two conditions:

- This device may not cause harmful interference.
- This device must accept any interference received, including interference that may cause undesired operation.

This equipment has been tested and found to comply with the limits for a Class B digital device, pursuant to Part 15 of the FCC Rules. These limits are designed to provide reasonable protection against harmful interference in a residential installation. This equipment generates, uses, and can radiate radio frequency energy and, if not installed and used in accordance with the installation instructions, may cause harmful interference to radio communications. However, there is no guarantee that interference will not occur in a particular installation. If this equipment does cause harmful interference to radio or television reception, which can be determined by turning the equipment off and on, the user is encouraged to try to correct the interference by one or more of the following measures:

- Reorient or relocate the receiving antenna of the affected receiver.
- Increase the separation between the SiriusXM equipment and the affected receiver.
- Connect the SiriusXM equipment into an outlet on a circuit different from that to which the affected receiver is connected.
- Consult the dealer or an experienced radio/TV technician for help.

WARNING! The FCC and FAA have not certified Satellite Radio Receiver use in any aircraft (neither portable nor permanent installation). Therefore, Sirius XM Radio Inc. cannot support this type of application or installation.

Patent Information

It is prohibited to, and you agree that you will not, copy, decompile, disassemble, reverse engineer, hack, manipulate, or otherwise access and/or make available any technology incorporated in this product. Furthermore, the AMBE® voice compression software included in this product is protected by intellectual property rights including patent rights, copyrights, and trade secrets of Digital Voice Systems, Inc. The software is licensed solely for use within this product. The music, talk, news, entertainment, data, and other content on the Services are protected by copyright and other intellectual property laws and all ownership rights remain with the respective content and data service providers. You are prohibited from any export of the content and/or data (or derivative thereof) except in compliance with applicable export laws, rules and regulations. The user of this or any other software contained in a SiriusXM radio is explicitly prohibited from attempting to copy, decompile, reverse engineer, hack, manipulate or disassemble the object code, or in any other way convert the object code into human-readable form.

Environmental Information

Follow local guidelines for waste disposal when discarding packaging and electronic appliances.

This product is packaged with cardboard, polyethylene, etc., and does not contain any unnecessary materials.

WARNING: This product contains chemicals known to the State of California to cause cancer and birth defects or other reproductive harm.

Copyrights and Trademarks

©2012 Sirius XM Radio Inc. Sirius, XM and all related marks and logos are trademarks of Sirius XM Radio Inc. All other marks and logos are the property of their respective owners. All rights reserved.

Important Legal Notice About Your Subscription

Hardware and subscription sold separately. **Service will automatically renew and bill at then-current rates until you call us at 1-866-635-2349 to cancel. See our Customer Agreement for complete terms at www.siriusxm.com.** Fees and taxes apply. All fees and programming subject to change. Our satellite service is available only to those at least 18 and older in the 48 contiguous USA and DC. Our Sirius satellite service is also available in PR (with coverage limitations). Our Internet radio service is available throughout our satellite service area and in AK and HI. Certain channels are not available on our Internet radio service, including MLB® play-by-play.

Important Legal Notice About Installation

Installation instructions are provided for your convenience. You must determine if you have the knowledge, skills, and ability required to properly perform installation. Professional installation is recommended. SiriusXM shall have no liability for damage/injury resulting from the installation/use of any SiriusXM or other products. You must ensure that all products are installed in adherence with local laws and regulations and in such a manner as to allow a vehicle to be operated safely and without distraction. SiriusXM product warranties do not cover the installation, removal, or reinstallation of any product.



V200 Connect Vehicle Tuner INSTALLATION GUIDE

Sirius XM Radio Inc.
1221 Avenue of the Americas
New York, NY 10020

1.866.635.2349

siriusxm.com

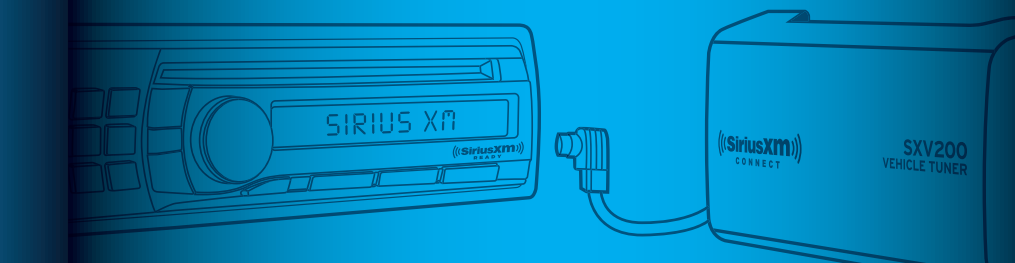

© 2012 Sirius XM Radio Inc.

SXV200V1 Installation Guide (SXV200V1IG1010) 111214b

